



TIGER

CRANES

Model 3215 Specifications

Model 3215 Specifications

Dimensional Specifications:

- 15' Reach
- 9-15' Hydraulic Boom Extension
- 12'8" Lifting Height (from base of crane)
- 34" Storage Height (from base of crane)
- 119" Overall Storage Length
- 14"X14" Mounting Space Required
- 12" Square Bolt Mounting Pattern
- 1/4" X 80' Aircraft Winch Cable
- 745 lbs. Operating Weight

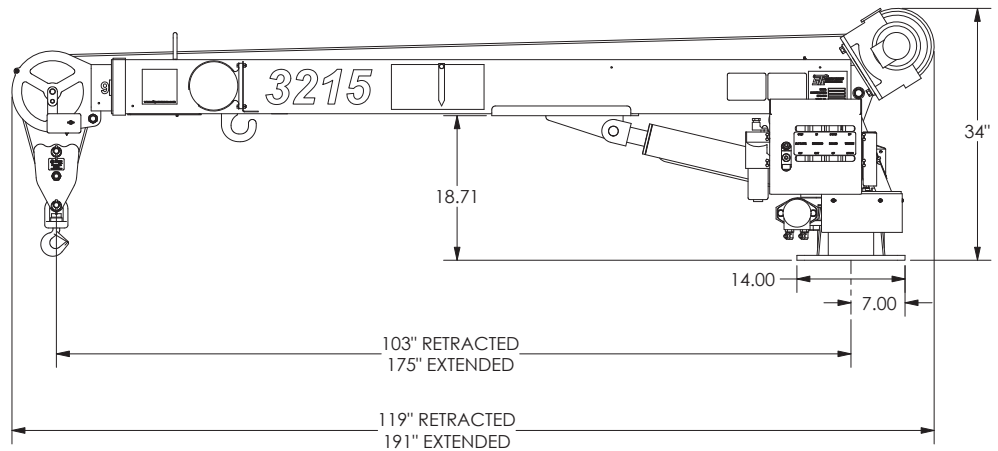

Performance Specifications:

- 11,000 ft-lb Crane Rating
- 13,300 ft-lb Maximum Crane Lifting Moment
- 3200 lb Double Line Lift Capacity
- 38 FPM Single Line No Load Speed
- 400 Degrees Rotation
- -7 Degrees to +77 Degrees Boom Elevation Positions

Standard Features:

- Wireless Control with 2 way remote to receiver communication, including 4 hydraulic functions with proportional trigger, horn button, engine start/stop switch and engine speed control and accessory switch. Requires 4 AA batteries.
- Load percentage indication with 4 character display on remote.
- 33' tether cable included for operation without batteries or in areas where radio transmission is not allowed.
- Anti two block & overload protection with condition indicators on remote.
- Sealed turret
- Integrated filtration with bypass condition indicator.
- 12 VDC DO3 10 GPM solenoids with manual overrides & LED On/Off indicator DIN connectors
- Hydraulic planetary winch. Boom mounted for easier stowing.
- Crane lift and extension cylinders are equipped with counterbalance safety valves.
- Powder coated base, turret shield and inner boom, with PPG Delfleet polyurethane paint on other components.
- This crane is designed to meet the requirements of ANSI/ASME B30.5 (2011) and OSHA 1910.180.

Minimum Requirements:

- 11,000 lbs. GVW Rating
- 60" Cab to Axle
- 4 GPM @ 2400 PSI - open center hydraulics
- 11,000 ft-lb rated crane tower reinforcement and outrigger

